

VOLANTEX RC



MINI
TRAINSTAR

RADIO CONTROL PRODUCTS

USER MANUAL

WARNING

The following terms are used throughout the product literature to indicate various levels of potential harm when operating this product.

CAUTION: Procedures, which if not be properly followed, is able to create a possibility of physical property damage AND or possibility of injury.

 Read the **ENTIRE** instruction manual to become familiar with the features of the product before operating. Fail to operate the product correctly can result in damage to the product, personal property and cause serious injury.

 This is a sophisticated hobby product and **NOT a toy**. It must be operated with caution and common sense and requires some basic mechanical ability. Fail to operate this Product in a safe and responsible manner could result in injury or damage to the product or other property. This product is not intended for use by children without direct adult supervision. Do not attempt to disassemble, use with incompatible components or augment product in any way without the approval of VolantexRC Co., Ltd..

This manual contains instructions for safety, operation and maintenance. It is essential to read and follow all the instructions and warnings in the manual, prior to assembly, setup or use, in order to operate correctly and avoid damage or serious injury.

Age Recommendation: Not for children under 14 years. This is not a toy.

Safety Precautions

As the user of this product, you are solely responsible for operating in a manner that does not endanger yourself and others or result in damage to the product or the property of others.

- Always ensure all batteries have been properly charged before using the vehicle.
- Always check all servos and their connections prior to each run.
- Never operate your vehicle near spectators, parking areas or any other area that could result in injury to people or damage of property.
- Never operate your vehicle during adverse weather conditions. Poor visibility can cause disorientation and loss of control of your vehicle.
- Never point the transmitter antenna directly toward the vehicle. The radiation pattern from the tip of the antenna is inherently low.
- If at any time during the operation of your vehicle you observe any erratic or abnormal operation, immediately stop operation of your vehicle until the cause of the problem has been ascertained and corrected.

Charging Warnings

The battery charger included with your vehicle is designed to safely balance and charge the battery.

The battery charger included with your vehicle is designed to safely balance and charge the battery.

CAUTION: All instructions and warnings must be followed exactly. Mishandling of batteries can result in a fire, personal injury, and/or property damage.

- By handling, charging or using the included battery, you assume all risks associated with the battery.

- If at any time the battery begins to balloon or swell, discontinue using immediately. If charging or discharging, discontinue and disconnect.

Continue to use, charge or discharge a battery that is ballooning or swelling can result in fire.

- Always store the battery at room temperature in a dry area for best results.

- Always transport or temporarily store the battery in a temperature range of 40-120 °F (5-49°C). Do not store battery or your vehicle in a car or direct sunlight. If stored in a hot car, the battery can be damaged or even catch fire.

- Always charge batteries away from flammable materials.

- Always inspect the battery before charging and never charge damaged batteries.

- Always disconnect the battery after charging, and let the charger cool before next charge.

Box Contents

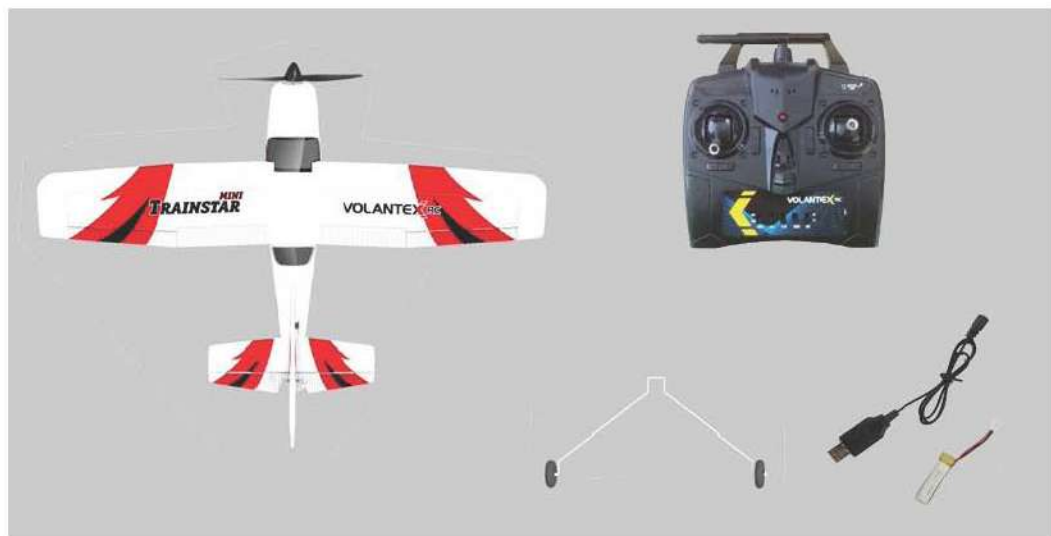

Setup Instruction

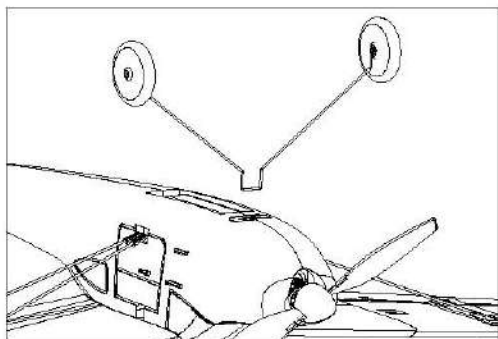

1. Plug landing gear in the slot of fuselage, making sure it is properly stuck in the slot.

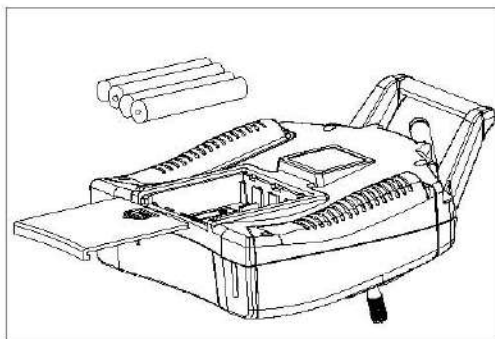

2. Install 4 AA batteries in transmitter.

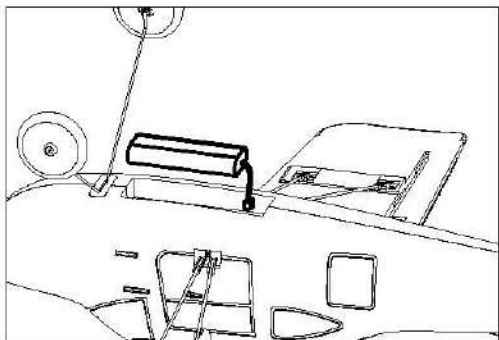

3. Connect battery to ESC, then stick the battery into the compartment with velcro, making sure the battery is well secured.



4. Setup is done. Follow below instructions to finish adjustment before start flying the vehicle.

Center Control Surfaces

With the transmitter turned on and the battery connected to the ESC (and installed in the battery compartment), it is now possible to check the center of all control surfaces.

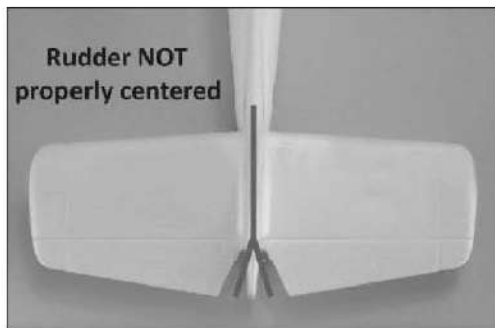
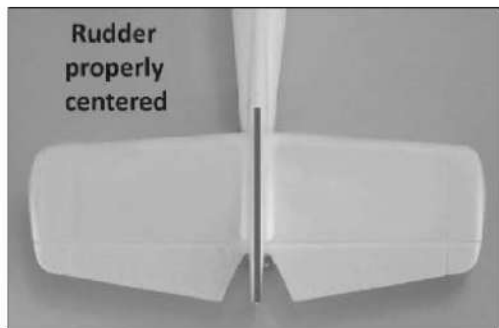

Observe the rudder to ensure it is properly centered as shown below.

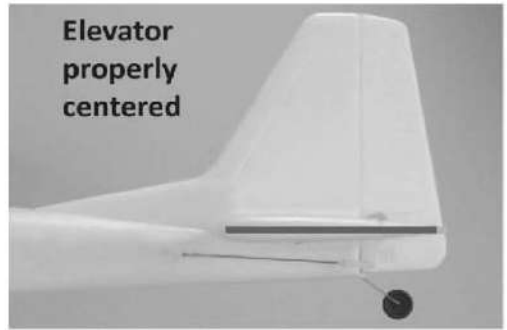

Then observe the elevator to ensure it is properly centered as shown below.

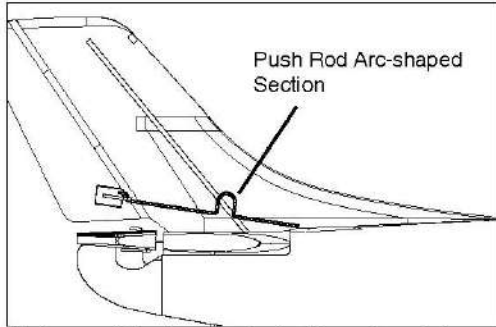

If the rudder is angled off to the right or left, adjust the push rod by its arc-shaped section slightly, making sure the rudder is properly centered.

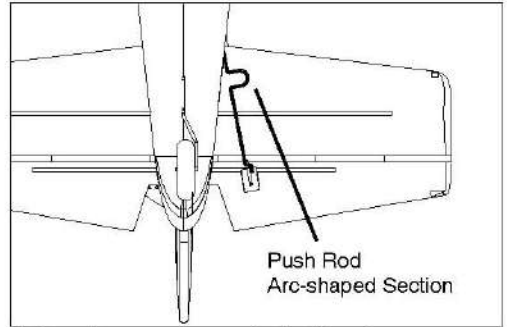

If the elevator is angled off to the upper or lower position, adjust the push rod by its arc-shaped section slightly, making sure the elevator is properly centered.

Transmitter Instruction



* Switch the knots to reverse position allowing channels to react to the oppsite direction.

WARNING: Do NOT switch to reverse position unless you are familiar with reverse function, or serious damage may occur!



Trainstar Mini comes with pre-installed Gyro to help control flying easily. To turn on the Gyro, switch the knot to upper position (towards you). To turn off the Gyro, switch the knot to lower position (away from you).

CAUTION: It is strongly suggested to turn on Gyro while flying Trainstar Mini, especially when it is flew by a beginner.

NOTE: Allow the airplane stay still about 5~7 seconds in a calm environment when you first time turn on Gyro, in order to calibrate.

Check The Control Surface And Channel Condition

Mode 1 & Mode 2: Depending on which area you are in, you will either use a Mode 1 or Mode 2 transmitter. The difference between the two modes deals with the throttle and elevator joystick. Mode 2 transmitter comes with the throttle control on the left stick and the elevator control on the right stick. Mode 1 is in the opposite way.

Before trying to fly the airplane, carefully check to make sure the transmitter and the servos work normally.

CAUTION: Make sure that you must turn on the transmitter firstly and then you can connect the battery. If you want to turn off the transmitter you must ensure that the battery of the plane must be cut off first.

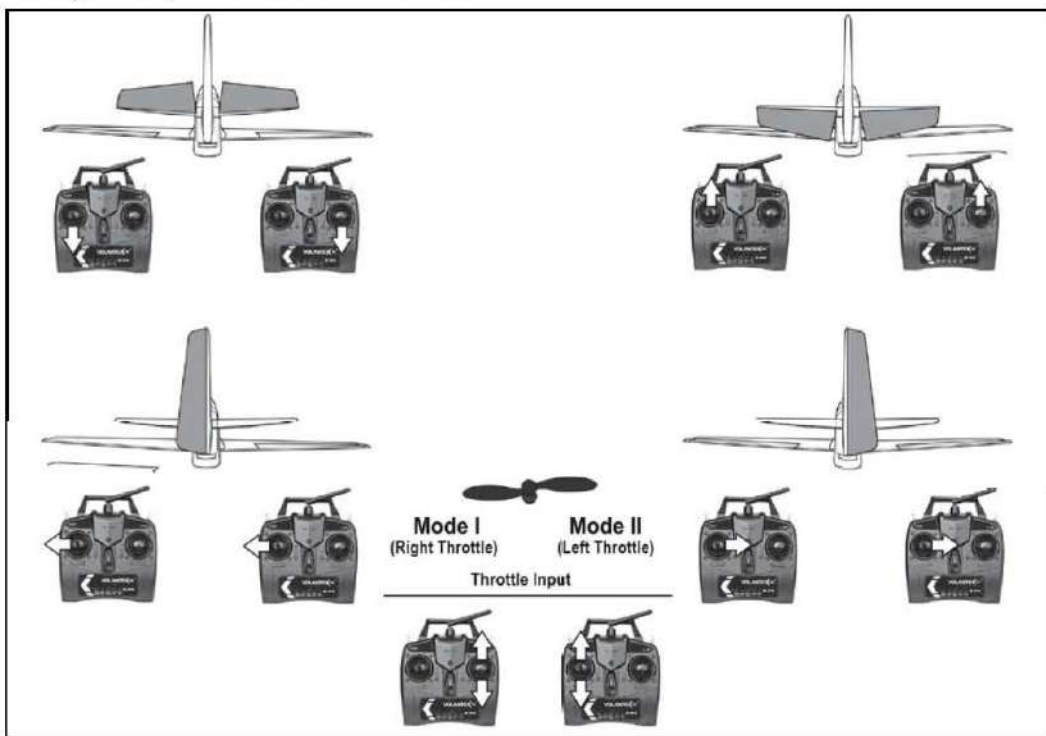

Find a Flight Field

Based on the size and weight of the plane it is typically considered to be a "park flyer" class airplane. As a result it is best to fly the plane at a local park, schoolyard, flying field or other area that is large enough and free of people and obstructions. We recommend an area the size of at least one football/soccer field. However, even larger areas are better suited and preferred especially when learning how to fly. Do NOT fly in parking lots, crowded neighborhood areas or in areas that are not free of people or obstructions.

We also suggest flying over grass as it is a much more forgiving surface that causes less damage in the unfortunate event or a crash. Short grass is better for takeoffs and landings as grass that is too long can cause the airplane to nose-over/flip and be damaged. An ideal flying area allows for takeoffs and landings on a smoother surface (such as asphalt) and flying over grass.

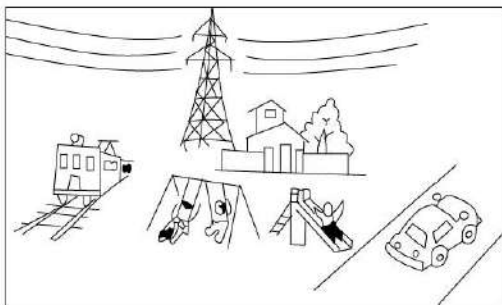
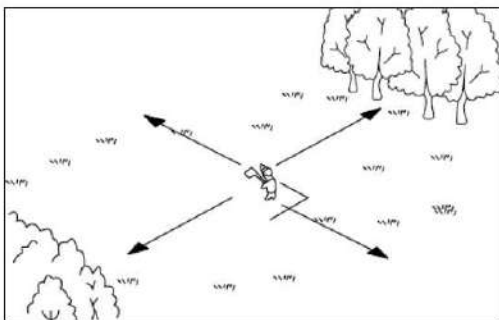

Fly in spacious ground without obstacles and boskage.

Never fly the plane near highway, railway, high tension line, crowded people, flying area and residential area.

NOTE: The plane is designed to be flew outdoors only.

Flying Conditions

It is typically best to fly on days that are calm without wind, especially when learning how to fly. It is strongly suggested flying only in calm conditions until you are familiar with the controls and handling of the model. Even light winds can make it much more difficult to learn to fly, and in some cases can even carry the model beyond your line of sight.

Also, if you are a first-time or low-time pilot, we highly recommend that allow a more experienced pilot to test fly and properly trim the model before attempting your first flight. A proven flyable and properly trimmed model is significantly easier and more enjoyable to fly.

After you have properly trimmed the airplane in calm conditions and become familiar with its handling/capabilities you will be able to fly in light winds or depending on your experience and comfort level, in winds up to 5-7 mph.

Do NOT fly on days when significant moisture, such as rain or snow, is present.

Flight Checklist

NOTE: This checklist is NOT intended to replace the content included in this instruction manual. Although it can be used as a quick start guide, we strongly suggest that read all though the manual completely before proceeding.

- Always turn the transmitter on first.
- Ensure the throttle control stick is on the bottom position before connecting the battery.
- Fly the model(hand-launch or take off from a flat/level surface).
- Land the model(on a flat/level surface).
- Unplug the battery from ESC.
- Always turn off the transmitter last.

changes or modifications not expressly approved by the party responsible for compliance could void the user's authority to operate the equipment.

This equipment has been tested and found to comply with the limits for a Class B digital device, pursuant to Part 15 of the FCC Rules. These limits are designed to provide reasonable protection against harmful interference in a residential installation. This equipment generates, uses and can radiate radio frequency energy and, if not installed and used in accordance with the instructions, may cause harmful interference to radio communications. However, there is no guarantee that interference will not occur in a particular installation.

If this equipment does cause harmful interference to radio or television reception, which can be determined by turning the equipment off and on, the user is encouraged to try to correct the interference by one or more of the following measures:

- Reorient or relocate the receiving antenna.
- Increase the separation between the equipment and receiver.
- Connect the equipment into an outlet on a circuit different from that to which the receiver is connected.
- Consult the dealer or an experienced radio/TV technician for help.

Requency band: 2405MHz -2475MHz EIRP power: 0.4dBm

Hardware version/revision no.: KY-LY03T

Name: RADIO CONTROL PRODUCTS NO.761-1

Manufacturer: VOLANTEXRC CO.,LTD.

Address: 2nd Building Fuxi Dongqiao Industrial Park, Shanzhang Road Shantou,China

Importer: FDS CORPORATION LTD

12 BLUESTEM ROAD, RANSOMES EUROPARK ESTATE, IPSWICH, IP3 9RR, UNITED KINGDOM

VOLANTEX RC